

GRANT EZ-FIT FLUE GUIDE



Universal EZ-Fit Flue Systems to suit all Grant Vortex Condensing Boiler Ranges



EFFICIENT HEATING SOLUTIONS

BALANCED FLUE SYSTEMS

YELLOW SYSTEM, WHITE SYSTEM,
RED SYSTEM, GREEN SYSTEM

CONVENTIONAL FLUE SYSTEMS

ORANGE SYSTEM, GREEN SYSTEM

CLEARANCES AND DESIGN SERVICE

GUIDE TO FLUE CLEARANCES
MODULAR FLUE DESIGN SERVICE

SEPTEMBER 2008 EDITION

This cancels all previous issues

Round **Low Level** Balanced Flue Systems Stainless Steel

Low Level EZ-Fit Flue Kits 'YELLOW System'

Grant's low level balanced range of EZ-Fit flue Systems have been developed to make the installation of Grant boilers both quick and simple, whilst ensuring trouble free operation – even in the most exposed site conditions.

Reduces Installation Time

The round low level kits feature self-sealing ducts requiring no silicone or tape for joints, and the unique quick-fit connection arrangement ensures a perfect seal every time. In fact, the new telescopic flue system requires only two simple operations to complete the installation. The kits are compatible with all Grant boilers, except Outdoor Modules.

The Grant Flue Terminal

The flue terminal has a compact design, making it ideal for installations where the visual appearance is important. The new cone design reduces the possibility of condensate, produced in the combustion process, staining external wall surfaces or patio slabs.

Extension Kits

The flue kits are telescopic and available in short or standard options. For wall thicknesses greater than shown, three extensions are available which extend the flue by 225mm, 450mm or 675mm to a **maximum of four metres**. 90° and 45° elbows are also available to give a greater degree of flexibility when siting the boiler.

LOW LEVEL FLUE KIT with 90° elbow extension added

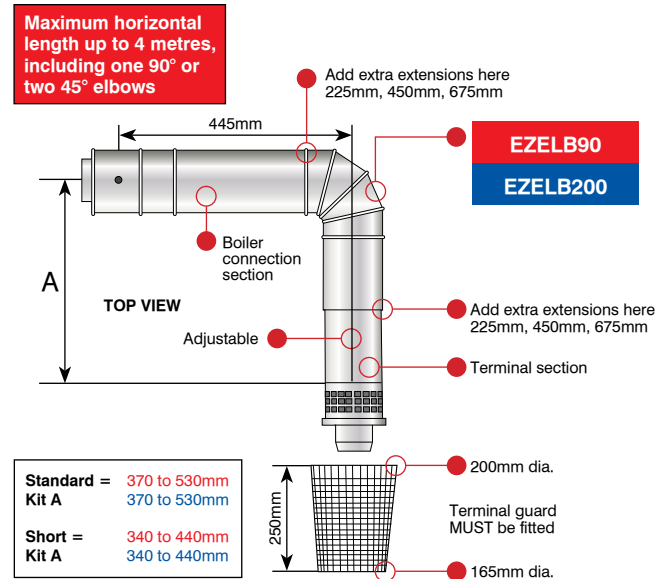

LOW LEVEL FLUE KIT [Stainless Steel]

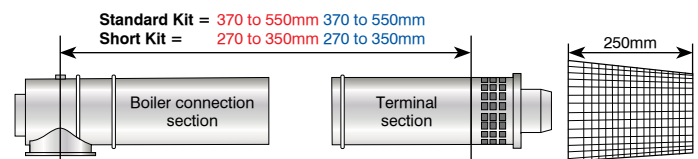

Contents of low level flue kit:

- Boiler connector section
- Terminal section
- Stainless steel flue guard
- Dress plate (not shown)
- Plugs and screws
- Side outlet cover trim (not shown)
- Lubricant (not shown)
- Snorkel clamp (not shown)

Low Level Balanced Flue Hole Cutting Dimensions

Model	Dimensions (mm)		
	A dia	B	C
Vortex Pro 15/21 & 15/26	127	115	768
Vortex Eco 12/21 & 21/26	127	115	768
Vortex Pro 26/36 & 36/46	162	115	780
Vortex Eco 26/35	162	115	780
Vortex Pro 46/58 & 58/70	162	112	1102
Vortex Pro Combi 21e & 26e	127	115	768
Vortex Pro Combi 36e	162	105	780
Vortex Eco Wall Hung 12/16 & 16/21	127	112	H + 765*

NOTE: *H is the height (mm) from floor to underside of boiler casing

NOTE: Dimension 'B' is given with the boiler pushed back against the rear wall. Any clearances must be added to 'B'.

NOTE: Flue diameters
123mm
152mm

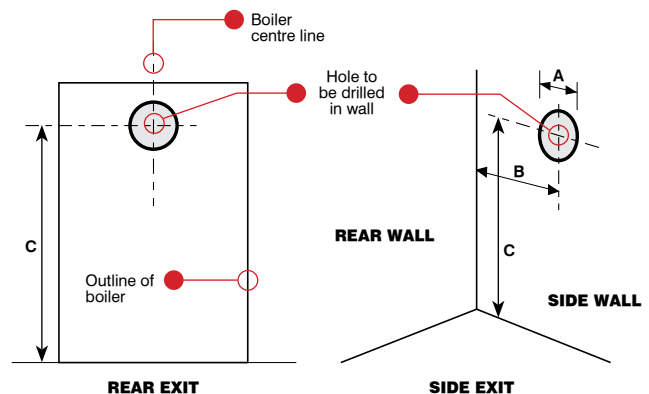

Order Part Reference Guide

LOW LEVEL BALANCED FLUE Kits

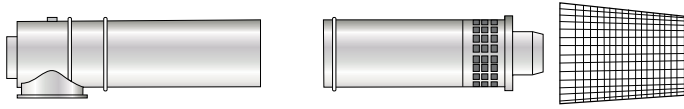

Standard Flue Kit	EZ90	Models up to 26kW
	EZ200	Models 26 - 70kW
Short Flue Kit	EZ90S	Models up to 26kW
	EZ200S	Models 26 - 70kW

LOW LEVEL BALANCED FLUE Extensions

IMPORTANT

FLUE EXTENSIONS CANNOT BE CUT. YELLOW SYSTEM EXTENSIONS ARE FOR HORIZONTAL USE ONLY AND CANNOT BE USED VERTICALLY WITH GREEN, ORANGE, RED OR WHITE SYSTEM COMPONENTS.

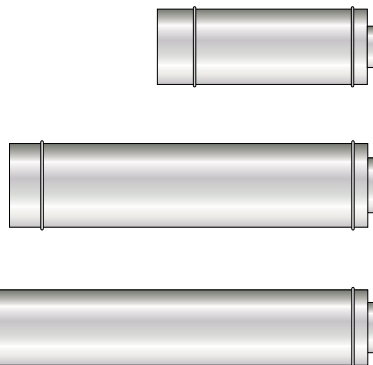

Extension 225mm	X90S	Models up to 26kW
	X200S	Models 26 - 70kW
Extension 450mm	X90M	Models up to 26kW
	X200M	Models 26 - 70kW
Extension 675mm	X90L	Models up to 26kW
	X200L	Models 26 - 70kW

IMPORTANT

HORIZONTAL LENGTHS UP TO 4 METRES CAN BE ACCOMMODATED, INCLUDING ONE 90° OR TWO 45° ELBOWS.

OFFSET ELBOWS

45° elbows can be used with low level kits to offset the flue. Extensions can be used between elbows.

Elbows directly connected

CODE	X	Y
EZ45/90S	120	260
EZ45/200S	130	280

LOW LEVEL BALANCED FLUE Accessories

IMPORTANT

EXTENDED ELBOWS ALLOW TELESCOPIC ADJUSTMENT FOR EXTENSIONS OR TERMINAL SECTIONS.

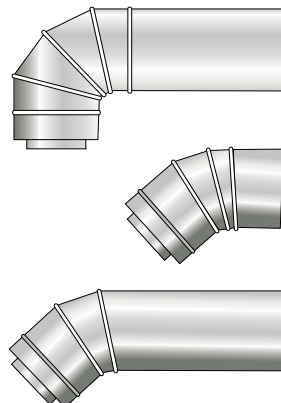

90° Elbow Kit	EZELB90	Models up to 26kW
	EZELB200	Models 26 - 70kW
45° Elbow Only	EZ45/90S	Models up to 26kW
	EZ45/200S	Models 26 - 70kW
45° Elbow Kit	EZ45/90	Models up to 26kW
	EZ45/200	Models 26 - 70kW

Internal High Level Balanced Flue Systems - White Powder Coated

High Level Balanced Flue Kits 'WHITE System'

High level balanced flue kits feature the same EZ-Fit boiler connections as the low level flue. The unique connection system on the high level flue ensures easy assembly thereby reducing installation costs.

Flexible Design

The kits may be extended horizontally and vertically. It is now possible to create offsets in standard high level flue systems by using our 45° elbows and extension kits – increasing the versatility of this new range.

Maximum Flue Length

High level balanced flues can be extended to a **maximum of 10 metres overall**, using the extension kits illustrated on Page 7. Deduct one metre for each additional 45° elbow used (maximum 6 elbows).

Dimensions

Section 'B' is the starter piece for the flue system and push fits into the boiler connector supplied with the kit. Section 'B' incorporates the air supply spigot and a combustion test point. Sections 'C' and 'D' combine to form a telescopic length. Terminal section 'F' slides over elbow 'E'. The horizontal length can be extended using the extensions listed. The adjustable extension cannot be connected to the terminal section 'F' – a fixed extension must be used. The vertical height can be extended using the extensions or 45° elbows listed. For short heights sections 'C' and 'D' may be omitted and elbow 'E' fitted to starter section 'B'.

Top Casing Height = X	
Model	X Dimensions (mm)
Vortex Pro 15/21 & 15/26	170
Vortex Eco 15/21 & 21/26	170
Vortex Pro 26/36 & 36/46	205
Vortex Eco 26/35	205
Vortex Pro 46-58 & 58/70	225
Vortex Pro Combi 21e & 26e	170
Vortex Pro Combi 36e	205
Vortex Eco Wall Hung 12/16 & 16/21	165

INTERNAL HIGH LEVEL FLUE KIT (White Powder Coated)

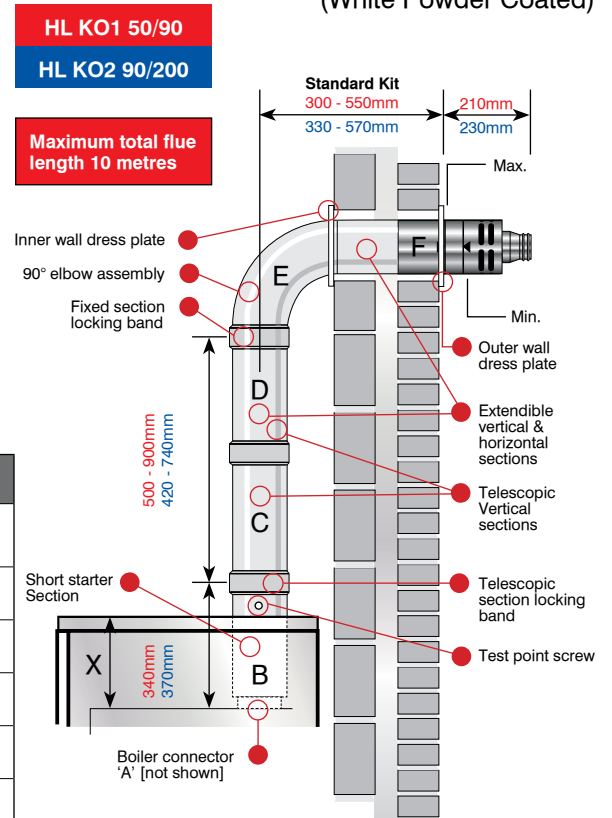

Contents of high level balanced flue kit:

- Boiler connector A
- Short starter section B
- Vertical telescopic section C/D
- Horizontal telescopic section [inc. terminal] E/F
- Locking bands
- Inner seals [red]
- Outer seal [black]
- Boiler connector
- Dress plates [inner & outer]
- Fitting Instructions

NOTE: For height adjustment see chart below.

High Level Balanced Flue Hole Cutting Dimensions

Model	Dimensions (mm)				
	A dia	B	C min	D min	D Max
Vortex Pro 15/21 & 15/26	175	115	1215	1715	2115
Vortex Eco 15/21 & 21/26	175	115	1215	1715	2115
Vortex Pro 26/36 & 36/46	200	115	1280	1700	2020
Vortex Eco 26/35	200	115	1280	1700	2020
Vortex Pro 46/58 & 58/70	200	112	1595	2015	2335
Vortex Pro Combi 21e & 26e	175	115	1215	1715	2115
Vortex Pro Combi 36e	200	105	1280	1700	2020
Vortex Eco Wall Hung 12/16 & 16/21	175	112	H + 1207*	H + 1707*	H + 2107*

NOTE: * H is the height (mm) from floor to underside of boiler casing

Standard kit with no extensions fitted.

NOTE: Flue pipe diameter: 150mm 180mm Excluding locking bands (SEE DIMENSION 'A' OPPOSITE FOR HOLE SIZE).

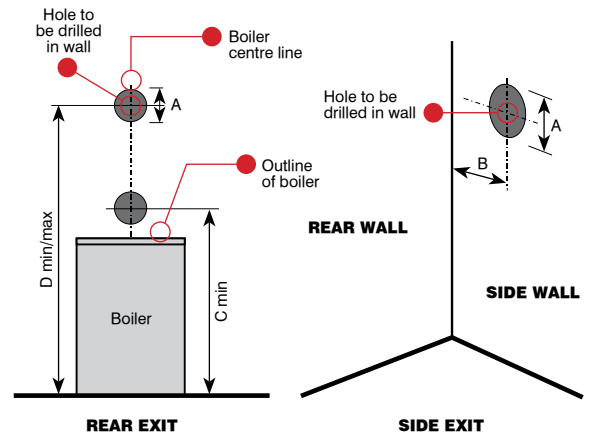

Order Part Reference Guide

HIGH LEVEL BALANCED FLUE KITS Internal

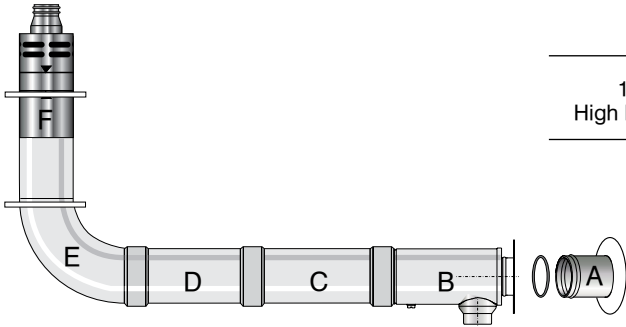

1.2 Metre High Level Flue Kit	HL K01 50/90	Models up to 26kW
	HL K02 90/200	Models 26 - 70kW

IMPORTANT
IF THE TERMINAL SECTION EXECUTES BELOW TWO METRES, A TERMINAL GUARD MUST BE FITTED.

HIGH LEVEL BALANCED FLUE KITS Internal

IMPORTANT
FLUE EXTENSIONS CANNOT BE CUT. WHITE SYSTEM EXTENSIONS ARE FOR HIGH LEVEL, VERTICAL AND RED SYSTEM INTERNAL USE ONLY AND CANNOT BE USED WITH YELLOW, GREEN OR ORANGE SYSTEM COMPONENTS.

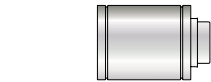

Extension 225mm C/W Locking Band	EXT K31 225/90	Models up to 26kW
	EXT K32 225/200	Models 26 - 70kW



Extension 450mm C/W Locking Band	EXT K09 450/90	Models up to 26kW
	EXT K10 450/200	Models 26 - 70kW



Extension 950mm C/W Locking Band	EXT K11 950/90	Models up to 26kW
	EXT K12 950/200	Models 26 - 70kW

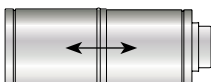

Adjustable Extension 275-450mm C/W Locking Band	EXT K13 ADJ/90	Models up to 26kW
	EXT K14 ADJ/200	Models 26 - 70kW

HIGH LEVEL BALANCED FLUE Accessories

IMPORTANT
HIGH LEVEL BALANCED FLUES CAN BE EXTENDED TO A MAXIMUM LENGTH OF 10 METRES USING THE EXTENSION KITS ILLUSTRATED ABOVE. DEDUCT ONE METRE FOR EACH ADDITIONAL 45° ELBOW USED (MAXIMUM 6 ELBOWS).



45° Elbow C/W locking Band	ELB K21 45/90	Models up to 26kW
	ELB K22 45/200	Models 26 - 70kW

IMPORTANT
A TERMINAL GUARD IS REQUIRED WHEN THE FLUE TERMINATES LESS THAN 2 METRES ABOVE OUTSIDE GROUND LEVEL. (NOT SUPPLIED BY GRANT).

OFFSET ELBOWS
45° elbows can be used with high level kits to offset the flue. Extensions can be used between elbows.

Elbows directly connected

CODE	X	Y
ELB K21	140	340
ELB K22	160	385

Elbows connected via fixed extensions

CODE	Extension used	X	Y
ELB K21	EXT225	300	500
	EXT450	455	665
	EXT950	810	1010
ELB K22	EXT225	320	545
	EXT450	475	700
	EXT950	830	1055

Elbows connected via adjustable extension

CODE	X	Y
ELB K21	335-455	535-655
ELB K22	355-475	580-700

Internal **Vertical** Balanced Flue Systems - White Powder Coated

Vertical Balanced Flue Kits 'WHITE system'

Vertical balanced flue kits share the same EZ-Fit boiler connections as our high level kits. The unique connection system on the vertical balanced flue ensures easy assembly thereby reducing installation costs.

Flexible Design

As with our high level kits it is now possible to create offsets in straight flue runs by using our 45° elbows and adjustable extension kits – increasing the versatility of this new range.

Maximum Vertical Flue Length

Vertical balanced flues can be extended to a maximum length of 12 metres in a straight run using the extension kits illustrated on Page 7. Deduct one metre for each additional 45° elbow used [maximum 6 elbows].

Dimensions

The dimensions shown are measured from the top of the boiler spigot, not the boiler case. The distance between the boiler flue spigot and the top of the casing should be taken into consideration. [See boiler installation manual].

Section (A) is the starter piece for the flue system and push fits into the boiler connector supplied with the kit. Section (B) incorporates the air supply spigot and a combustion test point.

Sections (B), (C) and (D) combine to form a telescopic length. Fixed extension (E) fits onto telescopic section (D). Terminal section (F) fits onto fixed extension (E).

For short flue heights section (E) may be omitted and the terminal section (F) may be fitted directly to section (D). The terminal section (F) overlaps section (D) by 50mm.

VT KO5 50/90
VT KO6 90/200

Maximum total flue length 12 metres

NOTE: Flue pipe diameter: 150mm 180mm
Excluding locking bands

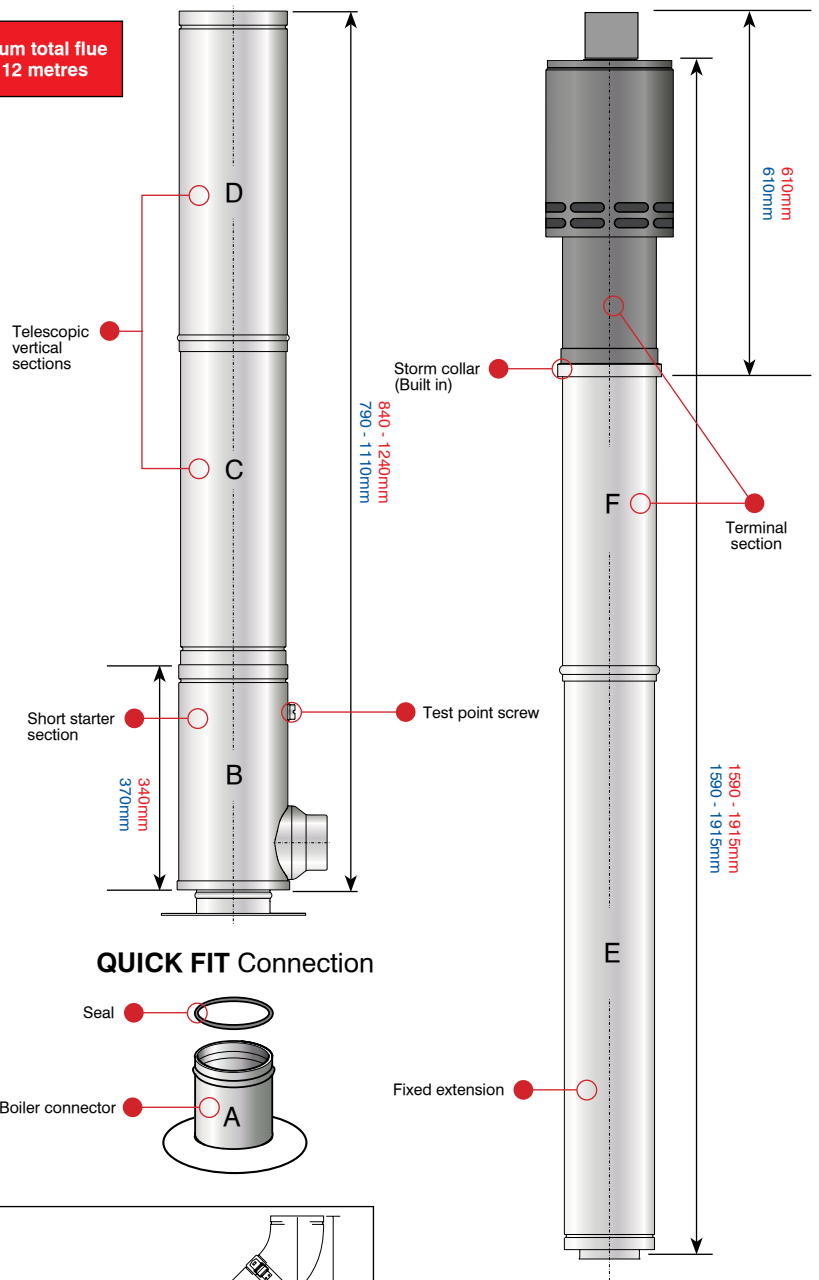

VERTICAL FLUE KIT (White Powder Coated)

Contents of 3 metre balanced flue kit:

- Boiler connector **A**
- Short starter section **B**
- Telescopic vertical sections **C/D**
- Fixed section 950mm **E**
- Terminal section **F** [inc.storm collar]
- Locking bands [not shown]
- Inner seals [red]
- Boiler connector
- Ceiling dress plate [not shown]
- Firestop spacers [not shown]
- Wall bracket
- Fitting Instructions

OFFSET ELBOWS

45° elbows can be used with high level kits to offset the flue. Extensions can be used between elbows.

Elbows directly connected

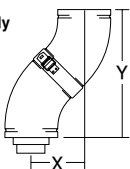

Elbows connected via fixed extensions

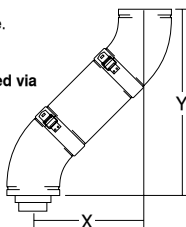

Elbows connected via adjustable extension

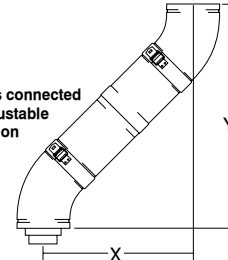

CODE	X	Y
ELB K21	140	340
ELB K22	160	385

CODE	Extension used	X	Y
ELB K21	EXT225	300	500
	EXT450	455	665
	EXT950	810	1010
ELB K22	EXT225	320	545
	EXT450	475	700
	EXT950	830	1055

CODE	X	Y
ELB K21	335-455	535-655
ELB K22	355-475	580-700



Order Part **Reference** Guide

VERTICAL BALANCED FLUE KITS Internal

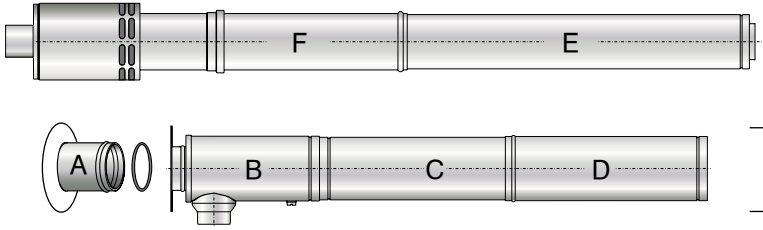

3 Metre Vertical Flue Kit	VT K05 50/90	Models up to 26kW
	VT K06 90/200	Models 26 - 70kW

VERTICAL BALANCED FLUE EXTENSIONS Internal

IMPORTANT

FLUE EXTENSIONS CANNOT BE CUT. WHITE SYSTEM EXTENSIONS ARE FOR HIGH LEVEL, VERTICAL AND RED SYSTEM INTERNAL USE ONLY AND CANNOT BE USED WITH YELLOW, GREEN OR ORANGE SYSTEM COMPONENTS.

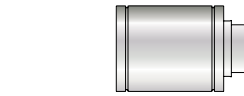

Extension 225mm C/W Locking Band	EXT K31 225/90	Models up to 26kW
	EXT K32 225/200	Models 26 - 70kW



Extension 450mm C/W Locking Band	EXT K09 450/90	Models up to 26kW
	EXT K10 450/200	Models 26 - 70kW



Extension 950mm C/W Locking Band	EXT K11 950/90	Models up to 26kW
	EXT K12 950/200	Models 26 - 70kW

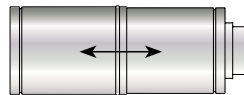

Adjustable Extension 275-450mm C/W Locking Band	EXT K13 ADJ/90	Models up to 26kW
	EXT K14 ADJ/200	Models 26 - 70kW

VERTICAL BALANCED FLUE Accessories



45° Elbow C/W locking Band	ELB K21 45/90	Models up to 26kW
	ELB K22 45/200	Models 26 - 70kW

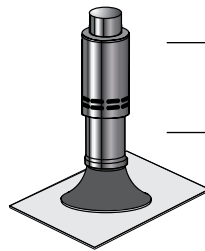

Flat Roof Flashing - Aluminium	VT K27 F90	Models up to 26kW
	VT K28 F200	Models 26 - 70kW

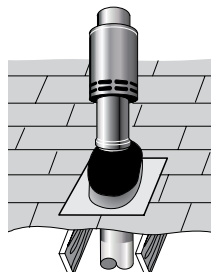

Pitched Roof Flashing - Aluminium	VT MF 90	Models up to 26kW
	VT MF 200	Models 26 - 70kW

Pitched Roof Flashing - Lead	VT K25 P90	Models up to 26kW
	VT K26 P200	Models 26 - 70kW



Wall Bracket	BRK 29 90	Models up to 26kW
	BRK 30 200	Models 26 - 70kW

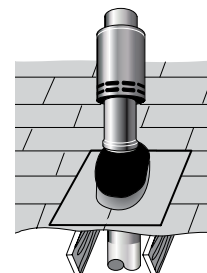

NOTE: Range of pitch 22°-45°

Flexible **Vertical** Balanced Flue Systems - Stainless Steel Inner Liner with Polypropylene Outer

Unique Flexi Vertical Balanced Flue Kits 'RED system'

The Grant Red System is the flexible balanced flue solution to nuisance plumbing and cold draughts. It is designed for Grant condensing boilers up to 26kW (90,000Btu/h) and allows an existing masonry chimney to be utilised rather than re-site the boiler and pipework.

Red System Kits

The Red System is supplied in two parts: Pack 1 consists of the boiler connector, adjustable extensions, bottom adaptor, terminal, plate and clamp. Pack 2 comprises two lengths of flexible vertical flue pipe (stainless steel and polypropylene) and is available in lengths for 6, 8, 10 and 12 metres.

Extensions and Elbows (From WHITE system)

The flexible vertical balanced flue kits share the same EZ-Fit flue extensions and elbows as the Grant 'White System'. This unique quick fit connection arrangement ensures easy assembly thereby reducing installation costs.

The maximum vertical straight length of the flue, from the top of the boiler to the top of the terminal, is 20 metres – **using no more than four 45° elbows.**

One metre of straight flue length should be deducted for every elbow used. If the flexible liner has to pass around an offset inside the chimney, two metres of straight flue length should be deducted to compensate for this i.e. equivalent two 45° elbows. Flue extensions cannot be cut, adjustable extensions should be used where required.

Maximum straight flue length from the boiler to the top of flue terminal = 20 metres.

NOTE: Flexi Flue pipe diameter:
Inner Diameter - 80mm
Outer Diameter - 125mm

IMPORTANT
THE GRANT RED SYSTEM SHARES
EXTENSION PIECES AND ELBOWS FROM
THE WHITE SYSTEM.

**OPTIONAL EXTRAS
(From White System)**

Rigid extensions
EXT K31 225/90
EXT K09 450/90
EXT K11 950/90

Adjustable extension
275-450mm
EXT K13 ADJ/90

45° elbow
ELB K21 45/90

OFFSET ELBOWS

45° elbows can be used with high level kits to offset the flue. Extensions can be used between elbows.

Elbows directly connected

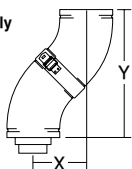

CODE	X	Y
ELB K21	140	340
ELB K22	160	385

Elbows connected via fixed extensions

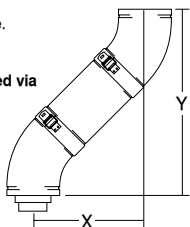

CODE	Extension used	X	Y
ELB K21	EXT225	300	500
	EXT450	455	665
	EXT950	810	1010
ELB K22	EXT225	320	545
	EXT450	475	700
	EXT950	830	1055

Elbows connected via adjustable extension

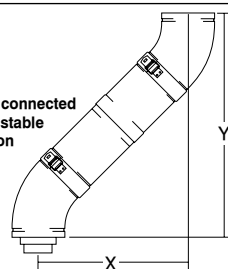

CODE	X	Y
ELB K21	335-455	535-655
ELB K22	355-475	580-700

RIGID TO FLEXIBLE BALANCED FLUE SYSTEM

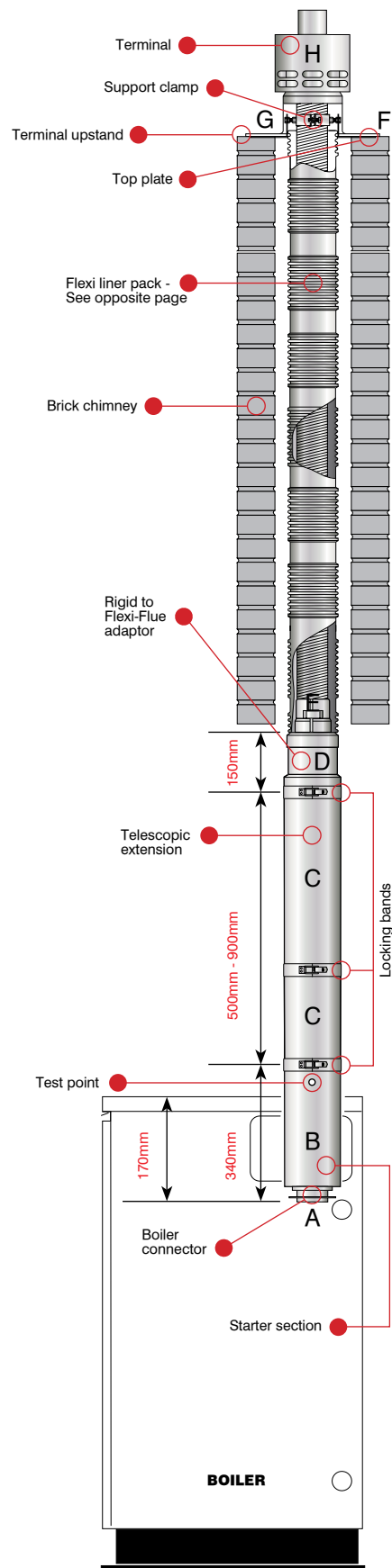

Order Part Reference Guide

PACK 1 Flexi Vertical Balanced Flue Connector

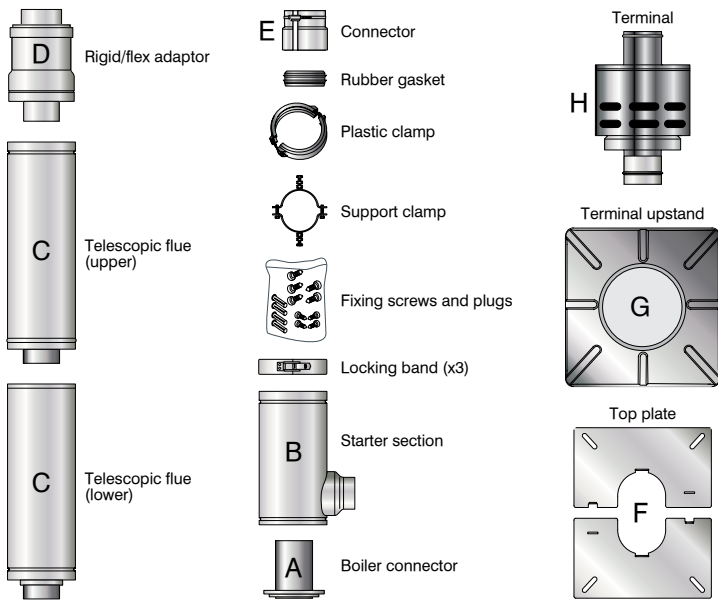

Red System Connector Pack	GFX CON KIT/26	Models up to 26kW
---------------------------	-----------------------	-------------------

IMPORTANT

RED SYSTEM KIT COMPRISES PACK 1 & PACK 2 IN REQUIRED LENGTH.

NOTE: Longer Flexi Balanced Flue Liner Kits are available by special order. Liners are directional and should be installed with the arrows facing upwards.

PACK 2 Flexi Vertical Balanced Flue Liner

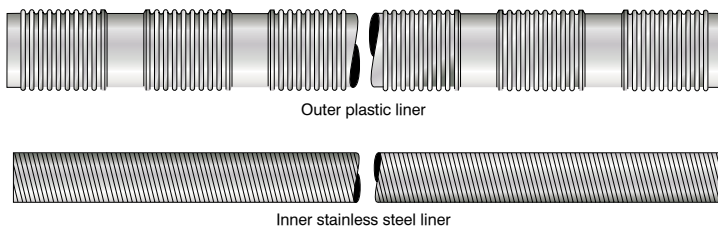

IMPORTANT

FLUE EXTENSIONS CANNOT BE CUT. WHITE SYSTEM EXTENSIONS ARE FOR HIGH LEVEL, VERTICAL AND RED SYSTEM INTERNAL USE ONLY AND CANNOT BE USED WITH YELLOW, GREEN OR ORANGE SYSTEM COMPONENTS.

6 Metre Flexible Liner Pack	GFX BF 6/26	Models up to 26kW
-----------------------------	--------------------	-------------------

8 Metre Flexible Liner Pack	GFX BF 8/26	Models up to 26kW
-----------------------------	--------------------	-------------------

10 Metre Flexible Liner Pack	GFX BF 10/26	Models up to 26kW
------------------------------	---------------------	-------------------

12 Metre Flexible Liner Pack	GFX BF 12/26	Models up to 26kW
------------------------------	---------------------	-------------------

RIGID FLUE EXTENSIONS & ELBOWS (From White System)

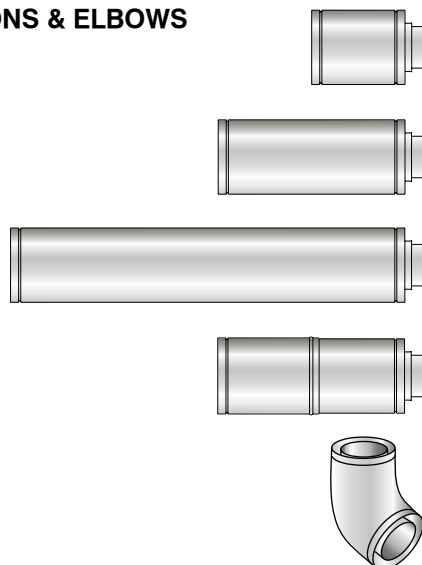

Extension 225mm C/W Locking Band	EXT K31 225/90	Models up to 26kW
----------------------------------	-----------------------	-------------------

Extension 450mm C/W Locking Band	EXT K09 450/90	Models up to 26kW
----------------------------------	-----------------------	-------------------

Extension 950mm C/W Locking Band	EXT K11 950/90	Models up to 26kW
----------------------------------	-----------------------	-------------------

Adjustable Extension 275-450mm C/W Locking Band	EXT K13 ADJ/90	Models up to 26kW
---	-----------------------	-------------------

45° Elbow C/W Locking Band	ELB K21 45/90	Models up to 26kW
----------------------------	----------------------	-------------------

External High Level/Vertical Flues - Stainless Steel

High Level/Vertical External EZ-Fit Flues 'GREEN System'

Grant's range of EZ-Fit Flue Systems have been extended to include 'external' high level and vertical options for all Grant condensing models. These new systems are supplied in a modular form, enabling most installations to be accommodated and are manufactured from high grade stainless steel.

Starter Flue Kits [Plume Diverter]

The Starter Flue Kit enables all internal boilers to be connected to an 'external' high level or vertical flue system, whilst maintaining the room sealed operation of the boiler. It is even possible to convert an existing EZ-Fit low level balanced flue kit to an external high level or vertical arrangement without any additional building work. This is particularly useful when plumbing from a low level flue terminal is a nuisance.

Maximum vertical length 8 metres. Maximum horizontal length 4 metres.

EXTERNAL FLUE SYSTEMS

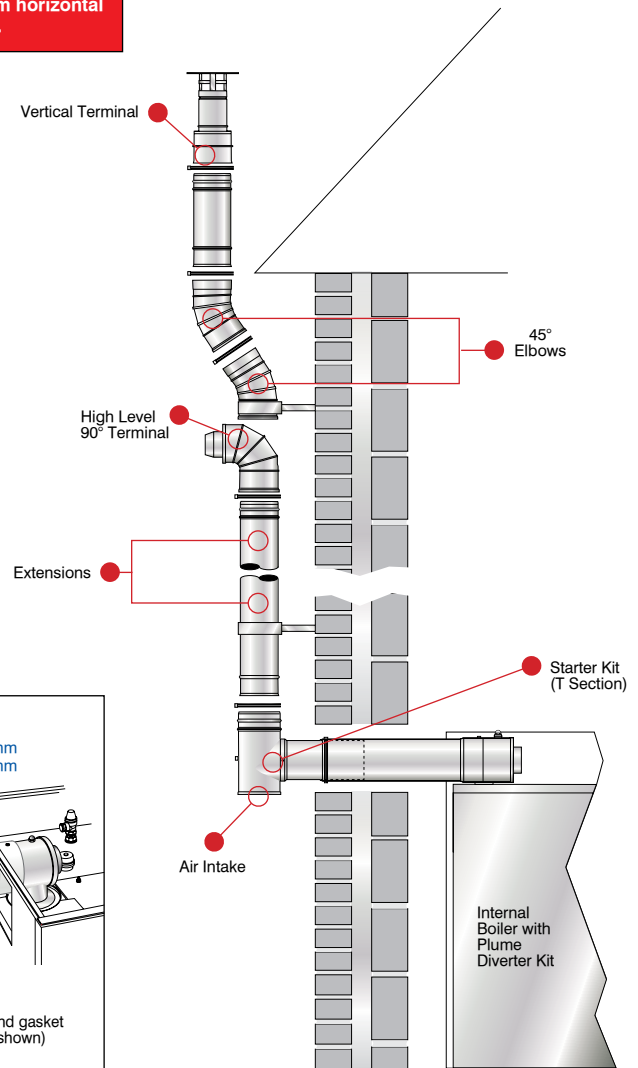

OFFSET ELBOWS

CODE	X	Y
GE45/90	126	304
GE45/200	142	343

45° elbows can be used with high level flues to create off-sets. Extensions can be used between elbows.

LOW LEVEL STARTER KITS

Standard Kit = 370 to 550mm 370 to 550mm
Short Kit = 270 to 350mm 270 to 350mm

Contents of low level Starter kit:

- Boiler connector section
- Tee section
- Side outlet cover trim
- Snorkel clamp (not shown)
- Dress plate
- Fixing clamp and gasket
- Lubricant (not shown)

Flue Hole Cutting Dimensions

Model	Dimensions (mm)		
	A dia	B	C
Vortex Pro 15/21 & 15/26	127	115	768
Vortex Eco 12/21 & 21/26	127	115	768
Vortex Pro 26/36 & 36/46	162	115	780
Vortex Eco 26/35	162	115	780
Vortex Pro 46/58 & 58/70	162	112	1102
Vortex Pro Combi 21e & 26e	127	115	768
Vortex Pro Combi 36e	162	105	780
Vortex Eco Wall Hung 12/16 & 16/21	127	112	H + 765*

NOTE: *H is the height (mm) from floor to underside of boiler casing

NOTE: Dimension 'B' is given with the boiler pushed back against the rear wall. Any clearances must be added to 'B'.

REAR EXIT

NOTE: Flue diameters 123mm 152mm

SIDE EXIT



Order Part Reference Guide

STARTER FLUE KIT High level/vertical external

IMPORTANT

STARTER FLUE KITS CAN BE EXTENDED HORIZONTALLY USING EXTENSIONS OR ELBOWS FROM THE LOW LEVEL BALANCED FLUE (YELLOW) SYSTEM ONLY SEE PAGE 3

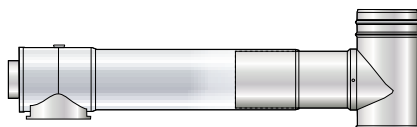

Standard Flue Kit	GK90	Models up to 26kW
	GK200	Models 26 - 46kW
Short Flue Kit	GK90S	Models up to 26kW
	GK200S	Models 26 - 70kW

FLUE EXTENSIONS High level/vertical stainless steel (Double skin)

IMPORTANT

FLUE EXTENSIONS CANNOT BE CUT. GREEN SYSTEM EXTENSIONS ARE FOR HORIZONTAL OR VERTICAL USE WITH CONVENTIONAL FLUE SYSTEMS ONLY AND CANNOT BE USED WITH YELLOW OR WHITE BALANCED FLUE COMPONENTS.

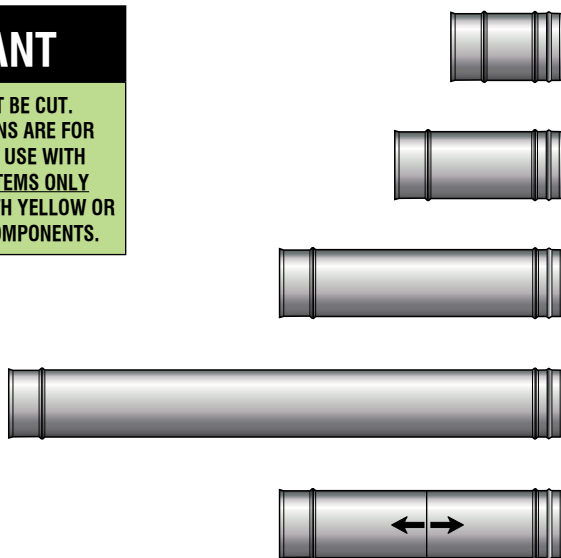

Extension 150mm C/W Locking Band	GX150/90	Models up to 26kW
	GX150/200	Models 26 - 46kW
Extension 250mm C/W Locking Band	GX250/90	Models up to 26kW
	GX250/200	Models 26 - 46kW
Extension 450mm C/W Locking Band	GX450/90	Models up to 26kW
	GX450/200	Models 26 - 46kW
Extension 950mm C/W Locking Band	GX950/90	Models up to 26kW
	GX950/200	Models 26 - 46kW
Adjustable Extension 195-270mm C/W Locking Band	GXA250/90	Models up to 26kW
	GXA250/200	Models 26 - 46kW

TERMINALS Stainless Steel

IMPORTANT

EXTENSION LENGTHS GIVEN ARE EFFECTIVE LENGTHS I.E. WHEN FITTED IN A FLUE SYSTEM.

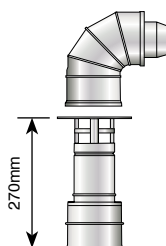

High Level 90° Terminal	GTH90	Models up to 26kW
	GTH200	Models 26 - 46kW
Vertical Terminal	GTV90	Models up to 26kW
	GTV200	Models 26 - 46kW

ACCESSORIES Stainless Steel

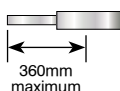
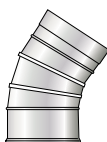

45° Elbow C/W Locking Band	GE45/90	Models up to 26kW
	GE45/200	Models 26 - 46kW
Extended Wall Bracket	GEB90	Models up to 26kW
	GEB200	Models 26 - 46kW
Wall Bracket	GWB90	Models up to 26kW
	GWB200	Models 26 - 46kW

Conventional Flue Systems - Stainless Steel

Conventional Flues For Grant Vortex Condensing Boilers ORANGE system

As many older oil fired boilers are traditionally connected to conventional flue systems, updating to a modern condensing boiler often results in the appliance needing to be relocated. The Grant EZ-Fit Conventional Flue System (Orange System) has been specifically designed to enable the existing chimney to be re-used and the boiler retained in its original position.

EZ-Fit Flexi Packs

Grant have developed a range of EZ-Fit Flexi Packs containing all the components required to utilise the existing chimney, including a smooth bore stainless steel flue liner, terminal, clamp plate and connectors for both the flex and boiler. All that is required to complete the installation is extension pipes or elbows from our Orange System accessories range.

Please note: the flexi liner should be installed with the directional arrows pointing upwards only.

Plumbing

Condensing boilers operate at extremely high efficiencies with cool flue gas temperatures, resulting in a plume of vapour being visible at the flue terminal. This plumbing (steam) is a normal condition of condensing boilers and indicates that the appliance is working efficiently. As an alternative to a low level, high level, or vertical balanced flue kit, utilising the original chimney with a Grant conventional flue Flexi-Pack moves the plume of vapour above roof level.

Combustion Air And Ventilation

An adequate permanent air supply is required for the safe operation of all open-flued (conventional flued) oil-fired appliances. For new or replacement boilers in properties built prior to the latest change to the Building Regulations (pre Approved Document L1A 2006) in England and Wales this ventilation must be in accordance with BS5410: Part1:1997. For installations in properties built or refurbished under the above current Building Regulations, the first 5kW of output should no longer be omitted for the purposes of calculating the ventilation area required.

RIGID TO FLEXIBLE CONVENTIONAL FLUE SYSTEM

Maximum vertical height from top of boiler to terminal 19 metres.

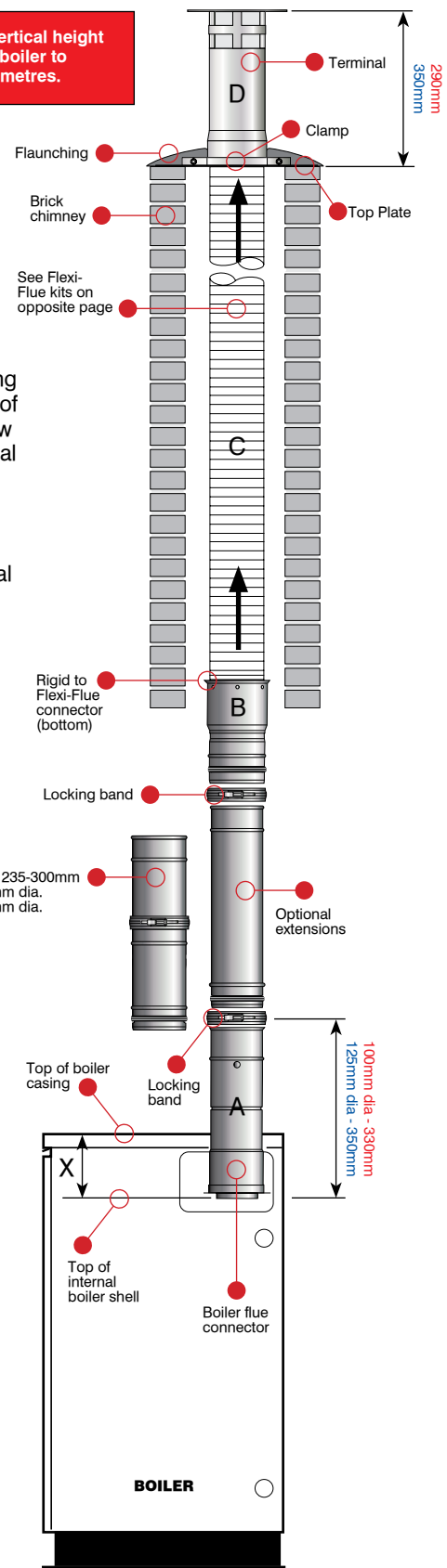

OFFSET ELBOWS

CODE	X	Y
WE45/100	126	304
WE45/125	142	343

45° elbows can be used with the Orange System to offset the flue. Extensions can be used between elbows.

IMPORTANT
FOR OPTIONAL EXTENSIONS AND ELBOWS - SEE PAGE 13

Top Casing Height = X	
Model	X Dimensions (mm)
Vortex Pro 15/21 & 15/26	170
Vortex Eco 15/21 & 21/26	170
Vortex Pro 26/36 & 36/46	205
Vortex Eco 26/35	205
Vortex Pro 46-58 & 58/70	225
Vortex Pro Combi 21e & 26e	170
Vortex Pro Combi 36e	205
Vortex Eco Wall Hung 12/16 & 16/21	165

OPTIONAL EXTRAS

Rigid extensions
WX 150/100
WX 150/125
WX 250/100
WX 250/125
WX 450/100
WX 450/125
WX 950/100
WX 950/125

Adjustable extension
235-300mm
WXA 250/100
WXA 250/125

45° elbow
WE 45/100
WE 45/125



Order Part Reference Guide

SMOOTH BORE FLEXI-FLUE KITS Stainless Steel (To suit Grant Vortex condensing boilers only)

CONTENTS OF FLEXI FLUE KITS:

NOTE: Silicone sealant and lubricating grease not shown. For assembly, see diagram on page 12.

6 Metre Flexible Flue Kit	GF KIT 6/100	Models up to 46kW
	GF KIT 6/125	Models 46 to 70kW
8 Metre Flexible Flue Kit	GF KIT 8/100	Models up to 46kW
	GF KIT 8/125	Models 46 to 70kW
10 Metre Flexible Flue Kit	GF KIT 10/100	Models up to 46kW
	GF KIT 10/125	Models 46 to 70kW
11 Metre Flexible Flue Kit	GF KIT 11/100	Models up to 46kW
	GF KIT 11/125	Models 46 to 70kW
12 Metre Flexible Flue Kit	GF KIT 12/100	Models up to 46kW
	GF KIT 12/125	Models 46 to 70kW
14 Metre Flexible Flue Kit	GF KIT 14/100	Models up to 46kW
	GF KIT 14/125	Models 46 to 70kW
16 Metre Flexible Flue Kit	GF KIT 16/100	Models up to 46kW
	GF KIT 16/125	Models 46 to 70kW

FLUE EXTENSIONS White powder coated (Single skin)

IMPORTANT

FLUE EXTENSIONS CANNOT BE CUT. ORANGE SYSTEM EXTENSIONS ARE FOR VERTICAL USE ONLY AND CANNOT BE USED WITH YELLOW OR WHITE SYSTEM COMPONENTS.

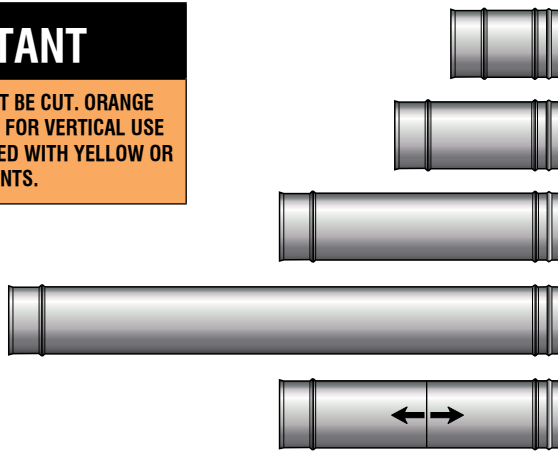

Extension 150mm C/W Locking Band	WX 150/100	Models up to 46kW
	WX 150/125	Models 46 to 70kW
Extension 250mm C/W Locking Band	WX 250/100	Models up to 46kW
	WX 250/125	Models 46 to 70kW
Extension 450mm C/W Locking Band	WX 450/100	Models up to 46kW
	WX 450/125	Models 46 to 70kW
Extension 950mm C/W Locking Band	WX 950/100	Models up to 46kW
	WX 950/125	Models 46 to 70kW
Adjustable Extension 235-300mm C/W Locking Band	WXA250/100	Models up to 46kW
	WXA250/125	Models 46 to 70kW

ACCESSORIES White powder coated

IMPORTANT

WHEREVER POSSIBLE INCORPORATE ONE ADJUSTABLE SECTION. NO MORE THAN TWO 45° ELBOWS CAN BE USED

IMPORTANT

EXTENSION LENGTHS GIVEN ARE EFFECTIVE LENGTHS I.E. WHEN FITTED IN A FLUE SYSTEM.

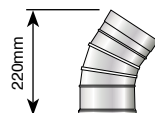

45° Elbow C/W Locking Band	WE45/100	Models up to 46kW
	WE45/125	Models 46 to 70kW

Hybrid **Conventional** Flue Systems - Interconnecting Grant Flue Systems

Using components from the Grant 'Orange' and 'Green' flue systems it is possible to construct bespoke flue systems to overcome specific boiler siting problems. For further information contact Grant's Technical Department on 01380 736920.

GREEN TO ORANGE SYSTEM

Stainless steel insulated external 'Green' system to flexi 'Orange' system - (See pages 11, 13 and 15)

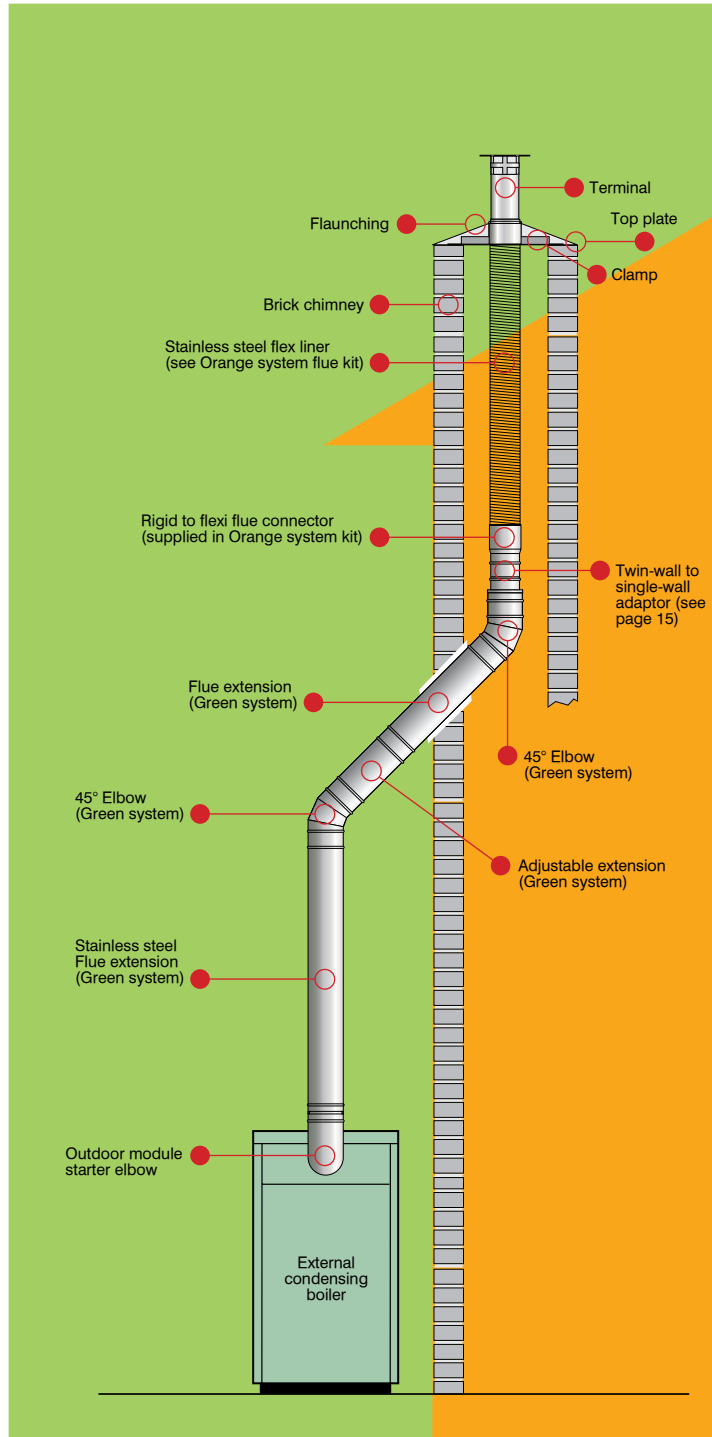

ORANGE TO GREEN SYSTEM

White powder coated internal 'Orange' system to external 'Green' system - (See pages 11, 13 and 15)

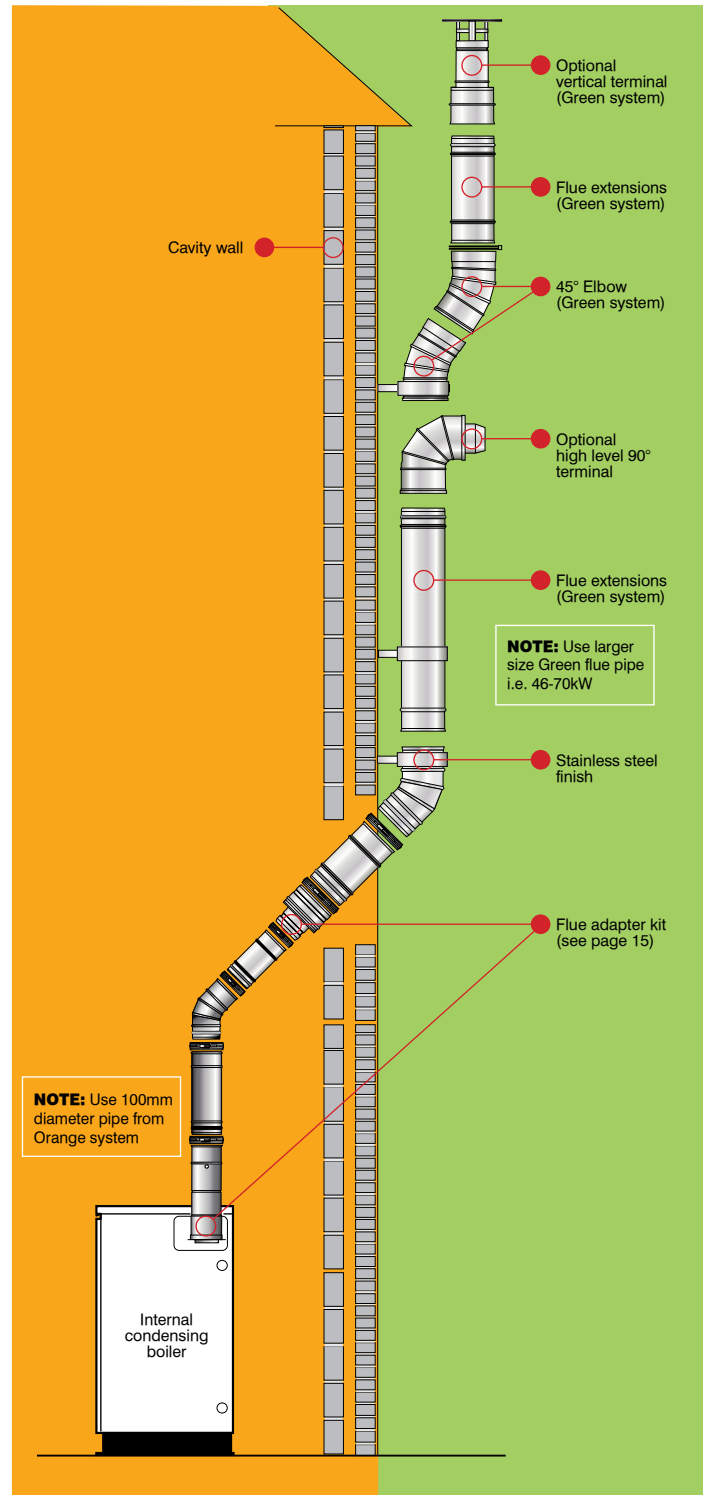

Hybrid **Conventional** Flue Systems - Interconnecting Grant Flue Systems - **EXTERNAL GREEN SYSTEM** - Outdoor Module

VERTICAL SOLUTION

See page 11 for extensions, elbows and terminals

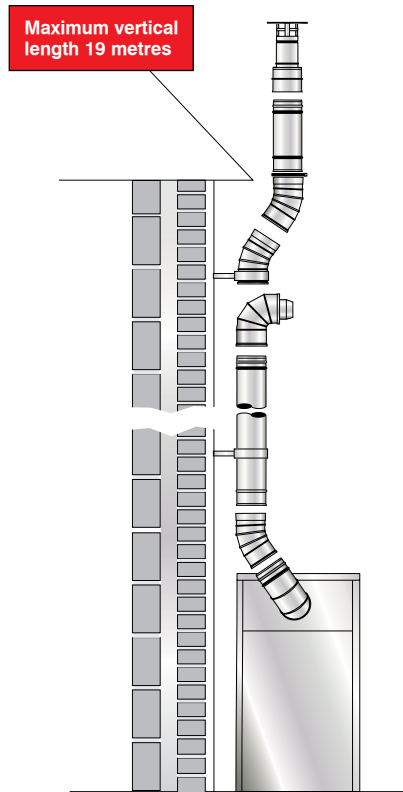

IMPORTANT
THE MAXIMUM NUMBER OF 45° ELBOWS WHICH CAN BE USED IS TWO.

IMPORTANT
COMPONENTS FROM THE ORANGE AND GREEN SYSTEM CAN BE USED TO CONSTRUCT INTERNAL HIGH LEVEL, OR VERTICAL CONVENTIONAL FLUE SYSTEMS USING THE FLUE ADAPTOR KIT CFA 15/70.

HORIZONTAL SOLUTION

See page 11 for extensions, elbows and terminals

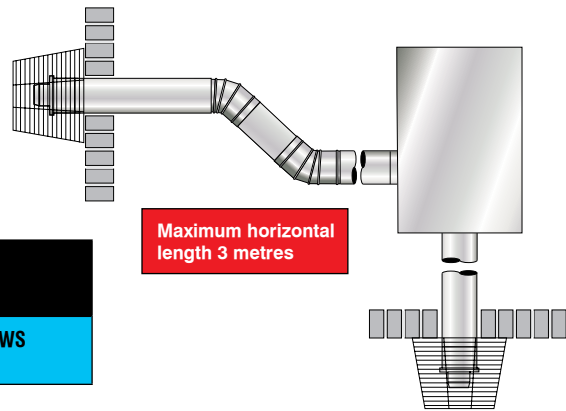

ECO WALL HUNG EXTERNAL

See page 11 for extensions, elbows and terminals.

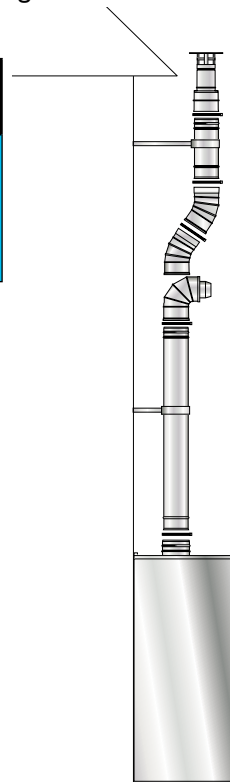

ACCESSORIES - External modules only

	External Module Starter Straight	GKM90C	Models up to 26kW
		GKM200C	Models 26 - 46kW
	External Module Starter Elbow C/W Test Point	GKM90	Models up to 26kW
		GKM200	Models 26 - 46kW
	Straight Terminal Only	GTL90	Models up to 26kW
		GTL200	Models 26 - 46kW
	Twin wall to single wall adapter	GFCON80	Models up to 26kW
		GFCON100	Models 26 - 46kW

FLUE ADAPTER KIT - Indoor boilers only

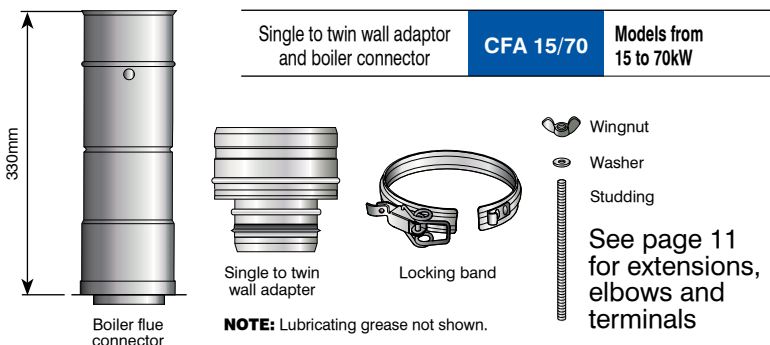

STARTER CONNECTORS

The Starter Elbow converts any of Grant's external modules or module combis to high level or vertical conventional flue operation.

The Starter Straight connector allows the low-level discharge flue system of any Grant external module or module combi to be extended horizontally.

The stainless steel flue components are fully insulated, have 'O' ring seals and locking bands, ensuring a rigid construction every time.

Clearance for **Balanced** Flues internal models

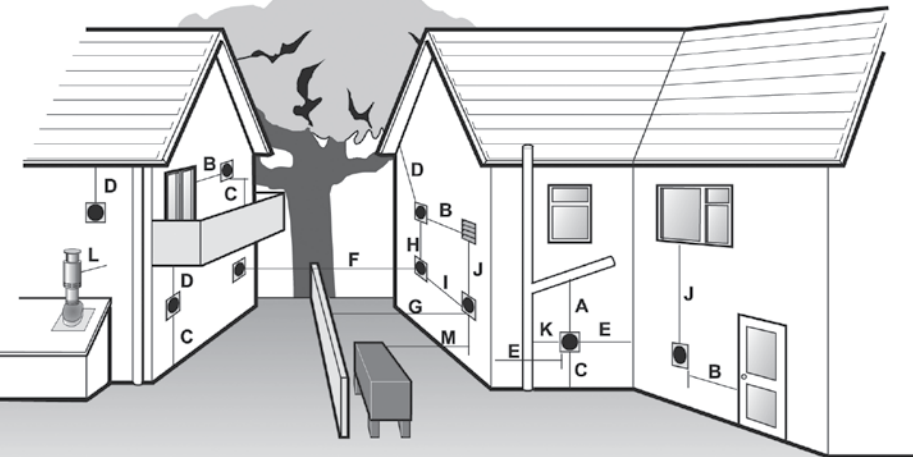

Clearance for **Balanced** Flues external modules

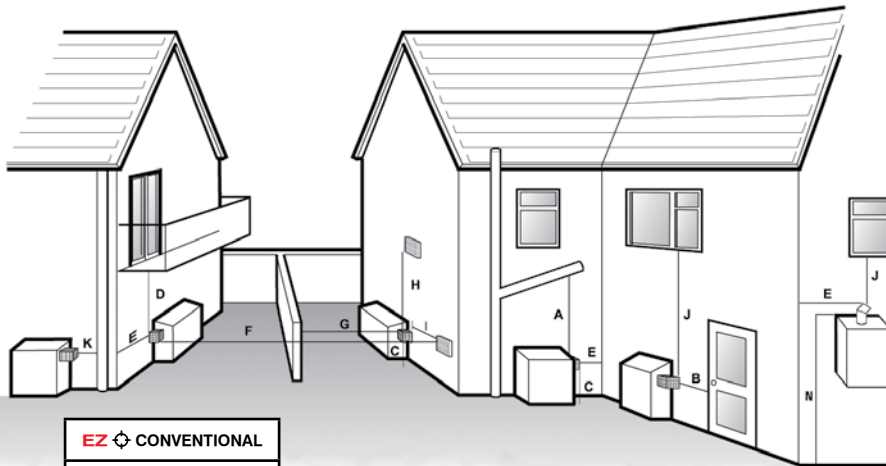

Ref	Position	mm
A	Below a gutter or sanitary pipework	*600
B	Horizontally from a door	600
C	Above ground or balcony level	300
D	Below eaves or balcony (without protection)	*600
E	From internal or external corner	**300
F	From a terminal facing a terminal	1200
G	From a surface facing a terminal	600
H	Vertical from terminals on the same wall	1500
I	Horizontal from terminals on the same wall	***750
J	Below an opening, airbrick, window etc.	600
K	From vertical sanitary pipework	300
L	Vertical flue from wall	750
M	From oil tank	1800
N	Minimum height from the ground	2000

NOTE: *75mm with protection **600mm for Outdoor Modules
***Only applies if one or both terminals are balanced flues.

Distance measured to rim of terminal. Clearances advised by Grant Engineering (UK) Ltd. in accordance with British Standards and Building Regulations.

The Terminal should be positioned so as to avoid products of combustion accumulating in stagnant pockets around the building or entering into buildings. Care should also be taken that the plume from a condensing flue does not cause a nuisance.

1. An opening means an openable element, such as a window, or a permanent opening such as a permanently open air vent.
2. Notwithstanding the dimensions given, a terminal should be at least 300mm from combustible material. e.g. a window frame.
3. A way of providing protection of combustible material would be to fit a heat shield at least 750mm wide.
4. Where possible it is always advisable to choose a high level or vertical flue option with condensing boilers to avoid nuisance pluming.

EZ CONVENTIONAL
FLUE DESIGN SERVICE

INDIVIDUALLY DESIGNED CONVENTIONAL FLUE SYSTEMS FOR MODULAR BOILER INSTALLATIONS

Grant UK offers a unique customised design service, where two or more boilers are connected in a modular form to a single conventional flue stack. This service includes the design and supply of flue headers and flue systems for standard and condensing boiler installations and is available to merchants upon completion of a simple site survey form. Contact our technical department on: **01380 736920** for further details.

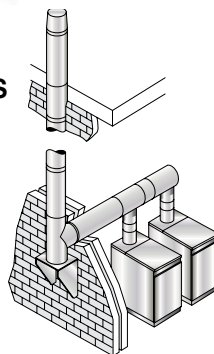

EFFICIENT HEATING SOLUTIONS

GRANT ENGINEERING (UK) LTD
HOPTON HOUSE, HOPTON INDUSTRIAL ESTATE,
DEVIZES, WILTSHIRE, SN10 2EU
T: 01380 736920 F: 01380 736991
E: SALES@GRANTUK.COM W: WWW.GRANTUK.COM

This leaflet is accurate at the time of printing but as Grant UK has a policy of continual improvement it may be superseded. We reserve the right to amend specifications without prior notice. The statutory rights of the consumer are not affected.

All products manufactured under I.S. EN ISO 9001.

™ THE GRANT 'EZ-FIT FLUE' SYSTEM is a Trade Mark of Grant Engineering Limited.

®Grant Vortex, Euroflame and Multi Pass are registered trade marks of Grant Engineering Limited. The contents of this leaflet are fully protected by copyright and nothing may be reproduced without permission from Grant UK.

